

GENUINE MUD FLAP (FRONT)

INSTALLATION AND USER'S INSTRUCTIONS

Thank you for purchasing a Genuine Mazda Accessory.

Before removal and installation, be sure to thoroughly read these instructions.



Please read the contents of this booklet to properly install and use the mud flap (front).

Your safety depends on it.

Keep these instructions with your vehicle records for future reference.



WARNING

- There are several  **WARNING** and  **CAUTION** sections in this booklet concerning safety when installing or removing the mud flap (front). Always read and follow the instructions in order to prevent injuries, accidents, and possible damage to the vehicle.

 **WARNING:** Indicates a situation in which serious injury or death could result if the warning is ignored.

 **CAUTION:** Indicates a situation in which bodily injury or damage to the vehicle could result if the caution is ignored.

- For areas indicating the tightening torque in this instruction manual, tighten to the specified torque using a torque wrench. For areas in which the tightening torque is indicated inside parentheses (), the tightening torque is indicated as a reference value, however tightening using a torque wrench is not necessary.
- Do not modify the mud flap (front).
- Do not install the mud flap (front) in any way other than described in the following instructions.
- If in any doubt, please contact your Mazda dealer to install the accessory in order to prevent errors in installation.
- If you have any questions about the use of the accessory, ask your Mazda dealer for proper advice before using it.
- Mazda and its suppliers are not responsible for injuries, accidents, and damage to persons and property that arise from the failure of the dealer or installer to follow these instructions.
- To ensure safety and reliability of the work, installation, removal and disposal work must be carried out by an Authorized Mazda Dealership.
- Be careful not to lose removed parts, and be sure that they are kept free of dirt, scratches, or damage.

PART NAME: MUD FLAP (FRONT)

PART NUMBER: KB7W V3 450 / KB8M V3 450 / KB9T V3 450A

VEHICLE: MAZDA CX-5 / MAZDA CX-8

NOTE

To the dealer

- Please give these instructions to the customer after installation.

To the customer

- Keep these instructions after installation. The instructions may be necessary for installing other optional parts or removal of this accessory.
- Should the vehicle or this accessory be resold, always give these instructions to the next owner.



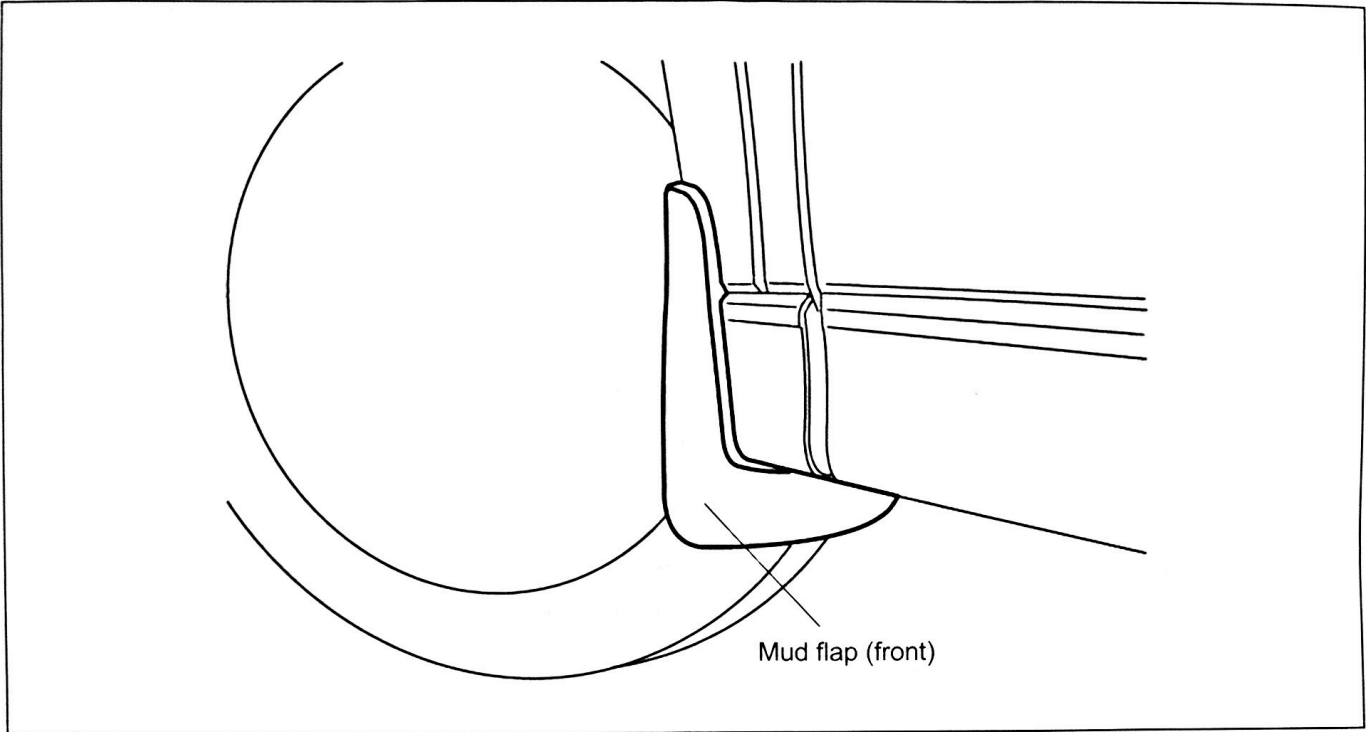



1. INSTALLATION VIEW



2. PARTS

NOTE

- Before installation, verify that the kit includes all the following parts and that they are free of dirt, scratches, or damage.

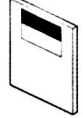
Part	Part name	Qty	Part	Part name	Qty	Part	Part name	Qty
	Mud flap (front) RH/LH	1 ea.		Bolt (includes sealant on thread area)	2		Clip nut	2
	Fastener ①	2		Fastener ②	2		Tapping screw	2
	Jack nut	2		Installation and user's instructions	1			

3. VERIFICATION ITEMS BEFORE INSTALLATION

■ REQUIRED TOOLS



- ☆ Phillips screwdriver
- ☆ Fastener remover wrapped with protective tape
- ☆ Jack nut tool
- ☆ Socket wrench (8 mm)
- ☆ Needle-nosed pliers
- ☆ Nipper
- ☆ Utility knife

⚠ WARNING

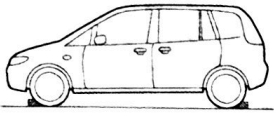
Before performing any work, park the vehicle on level ground, apply the parking brake securely, and then block the wheels. If the vehicle moves while performing work, it may cause injury.

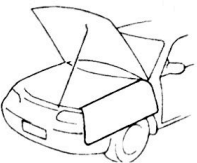
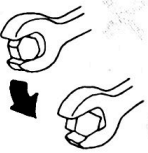
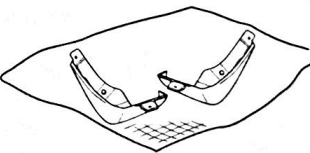

⚠ CAUTION

Use masking tape or a protector to prevent scratches when removing/installing parts.	Use the most appropriate (size, use) tool for each task and perform the work correctly. (Otherwise) the parts may be damaged.	Place the removed parts and kit accessories on a protective sheet to prevent scratches.	Wrap protective tape around screwdrivers and fastener remover tools to prevent scratching the vehicle.
			





ADVICE

Refer to the Workshop Manual for removal and installation of applicable vehicle parts.

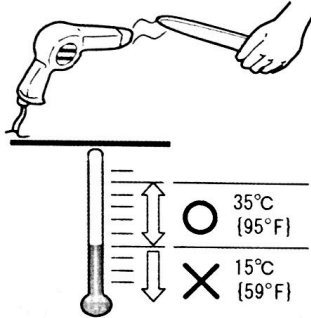
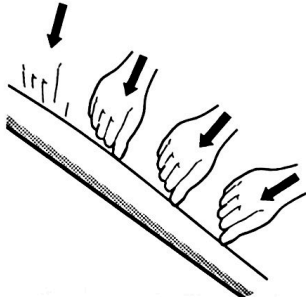

⚠ CAUTION (Double-sided adhesive tape usage)

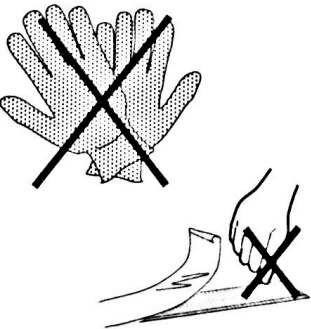
* Adhesion surface means the door or bumper, and part means the accessory.

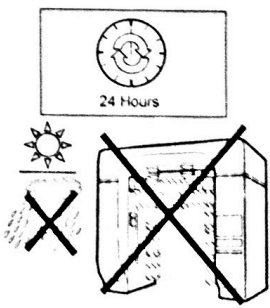
<p>Avoid ambient temperatures of 15 degrees C or less</p> <p>Because the adhesiveness of the adhesive depends on the softness of the resin, the adhesiveness decreases in cold temperatures (15 degrees C or less). Therefore, avoid servicing in ambient temperatures of 15 degrees C or less. If servicing has to be performed in ambient temperatures of 15 degrees C or less, heat the adhesion surfaces including the kit part sufficiently.</p>	<p>Adhere evenly</p> <p>To assure sufficient adhesiveness of the double-sided adhesive tape, press adhesive surface of the tape to adhesion surface evenly. In particular, press sufficiently at the ends of the double-sided adhesive tape where the adhesion surface is curved.</p>	<p>Clean adhesion surface</p> <p>If dirt or grease is left on the adhesion surface it will stick to the double-sided adhesive tape and decrease the tape's adhesive strength. Clean the adhesion surface before adhering the tape. Use mild detergent for the interior, and Isopropyl alcohol (IPA) for the exterior.</p>
		
<p>Keep tape clean</p> <p>If you touch the adhesive surface, oil on the skin will adhere to the adhesive and decrease the adhesive strength. When using cotton gloves, fiber or dirt may adhere to the tape. Be careful to keep the adhesive surface of the double-sided tape clean.</p>	<p>Surface treatment using promoter</p> <p>When plastic (such as material or unpainted part) is attached to the adhesion surface, surface treatment using a promoter is required to improve the adhesive strength of the installation. When performing surface treatment using a promoter, mask so that areas other than the adhesive side of the double-sided adhesive tape are not coated.</p>	<p>Handling after installation</p> <p>Because 24 hours is required for the installation to set, after installation, do not wash the car or park the car under rain during the 24 hour period. Otherwise, the adhesive strength will not be stable. Never re-adhere the part once its been installed. Otherwise, the adhesive strength will be extremely low.</p>
		

4. MUD FLAP (FRONT) INSTALLATION

• The figure shows the left side, however, perform the same procedure for the right side.

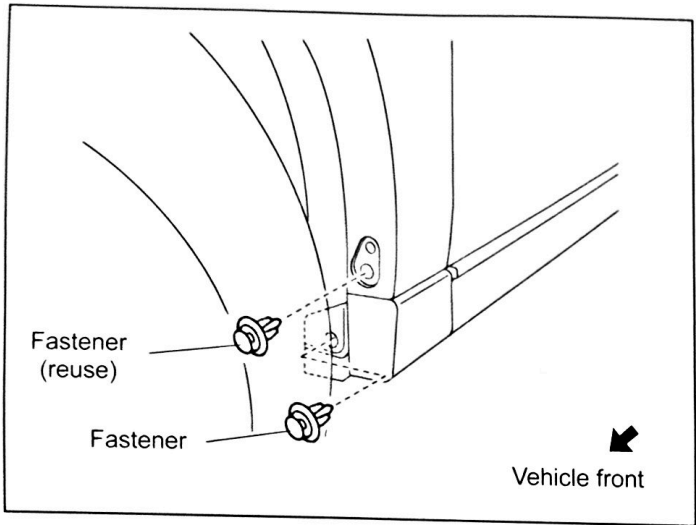

1. Remove the front over fender fasteners shown in the figure.

• Only one of the removed fasteners is to be reused.

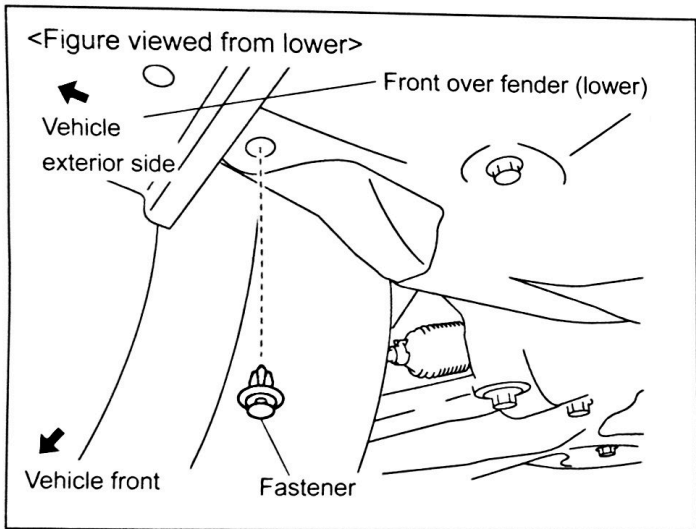

2. Remove the fastener on the underside of the vehicle body shown in the figure.

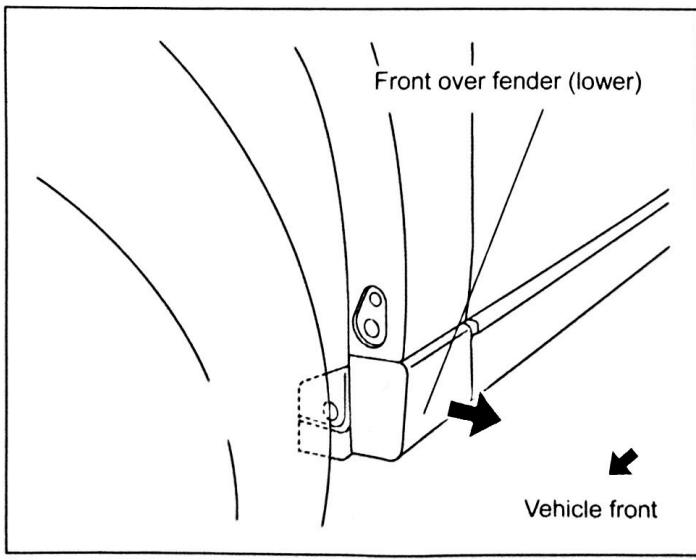

3. Grasp the flange on the vehicle interior side of the front over fender (lower) with your hand, pull it in the direction of the arrow and remove it. (Front over fender (lower) is secured by tabs in three locations.)

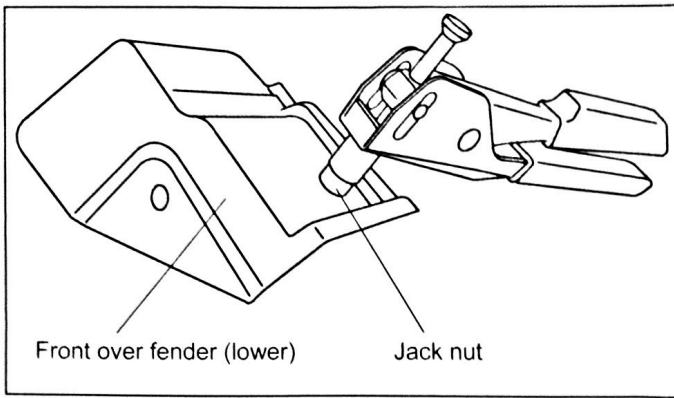

4. Install the jack nut to the hole on the underside of the removed front over fender (lower).

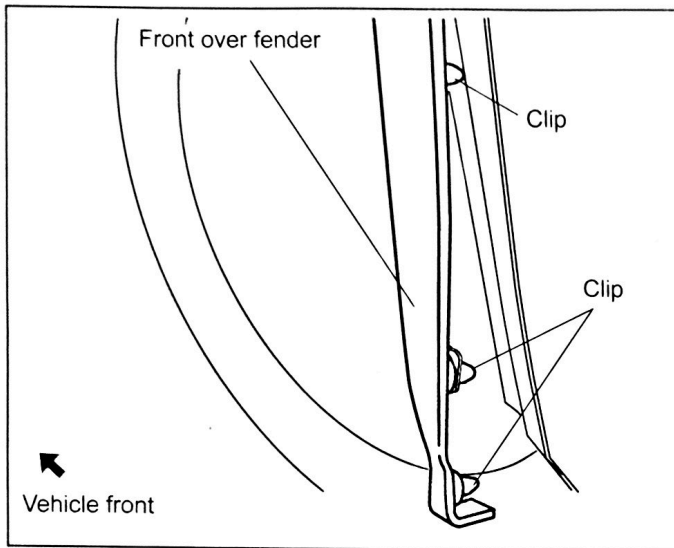

5. Remove the front over fender clips in the three locations from the bottom.

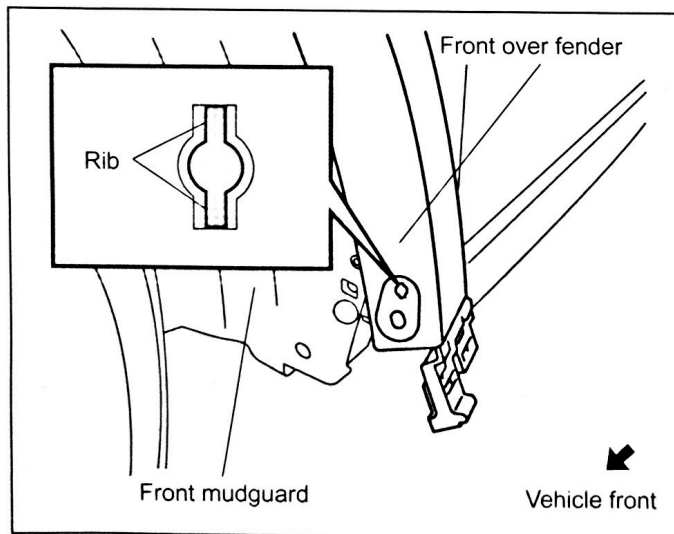

6. Cut out the rib of the front over fender shown in the figure using a nipper.

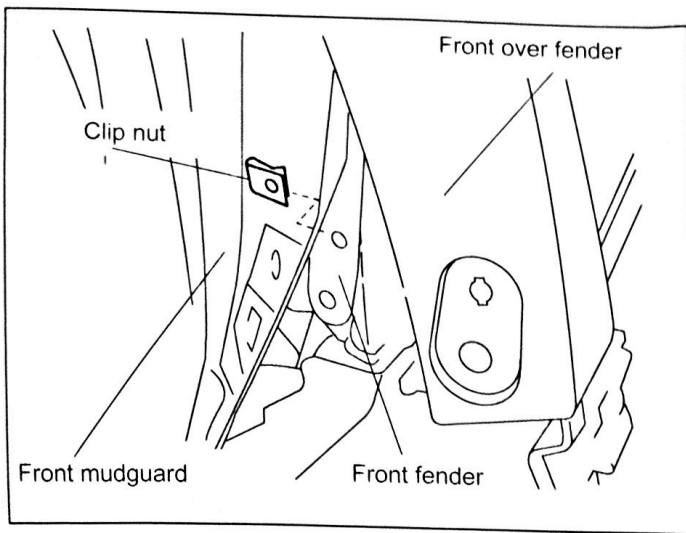

7. Peel back the front mudguard and front over fender, and install the clip nut to the position shown in the figure of the front fender.

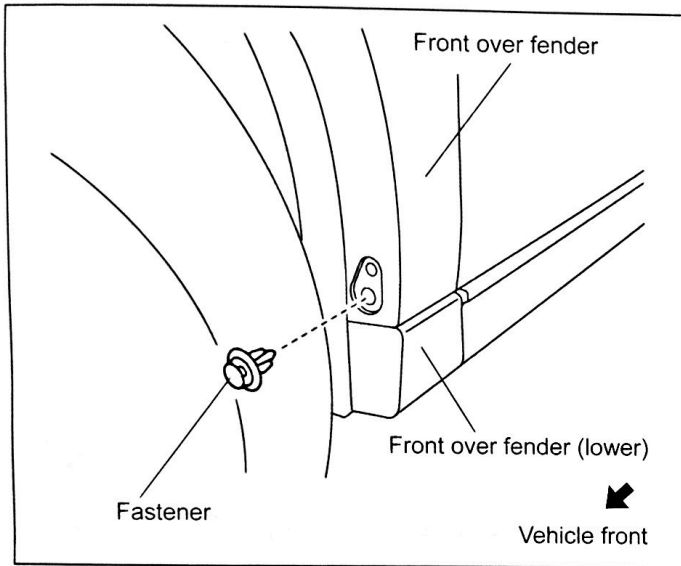

8. Re-install the front over fender and front over fender (lower) to their original positions and only install the one reusable fastener removed in Step 1.

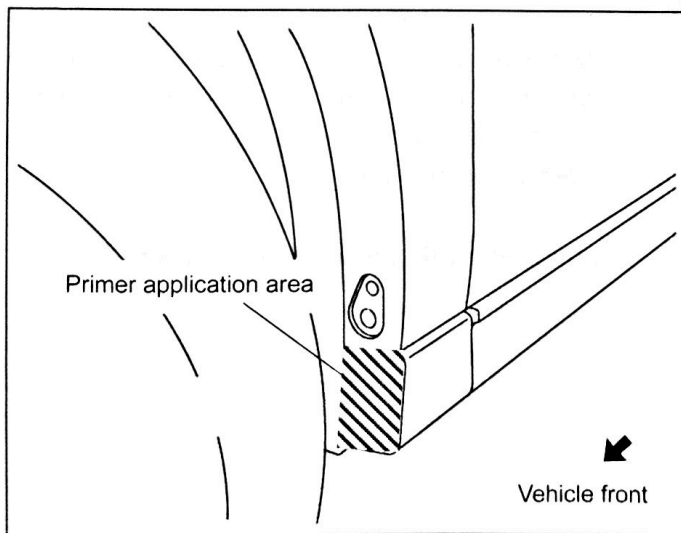

9. After removing the oil from the area of the front over fender (lower) shown in the figure using IPA or white gasoline, let it dry sufficiently, and then apply primer.

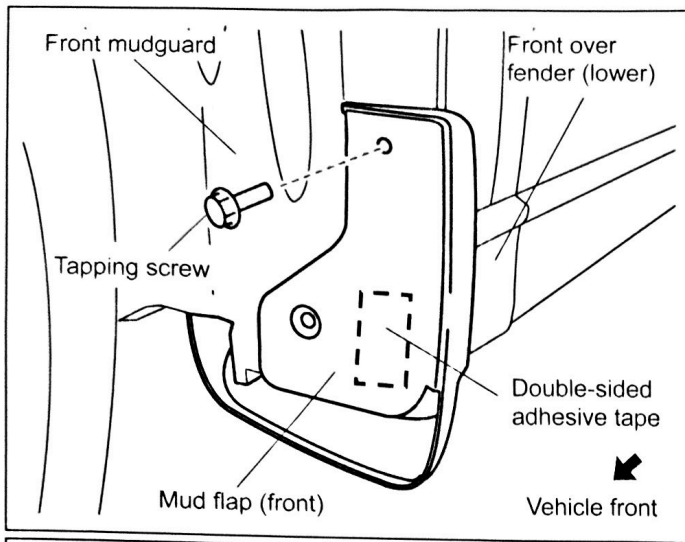

- Remove the paper backing from the double-sided adhesive tape on the mud flap (front), and temporarily tighten the tapping screw and bolt.

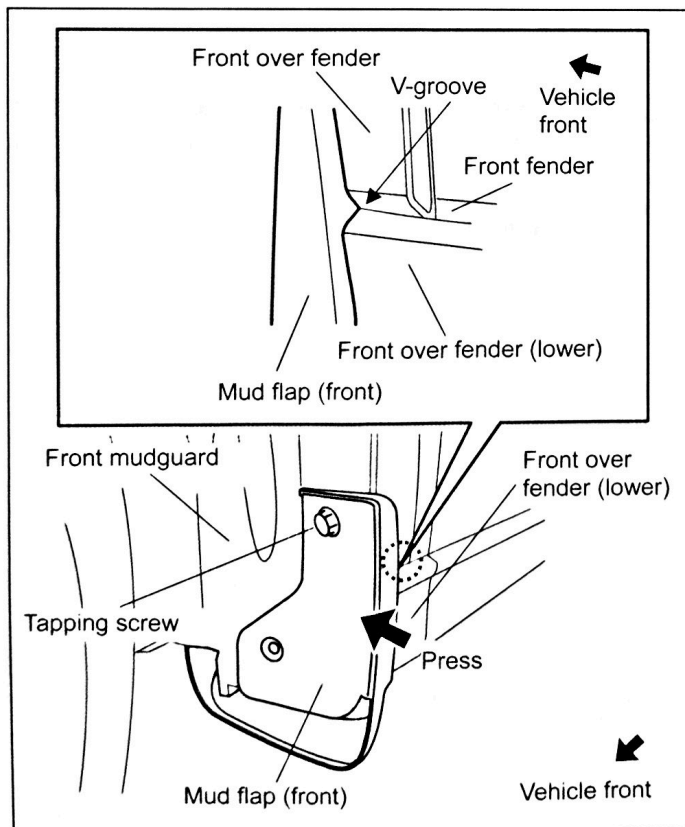
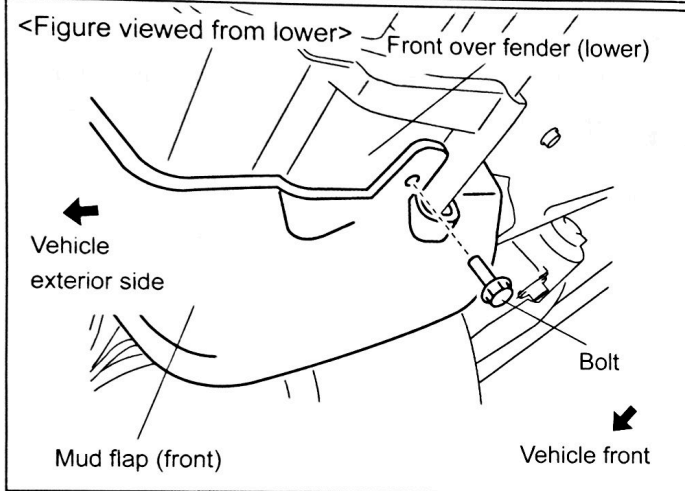

- Press the mud flap (front) in the direction of the arrow in the figure so that the gap between the contacting surfaces at the upper/lower area of the V-groove are uniform. Securely tighten the tapping screw so that there is no gap in the contacting surfaces with the front over fender and front over fender (lower).

Tapping screw tightening torque: (0.8 to 1.2 Nm)

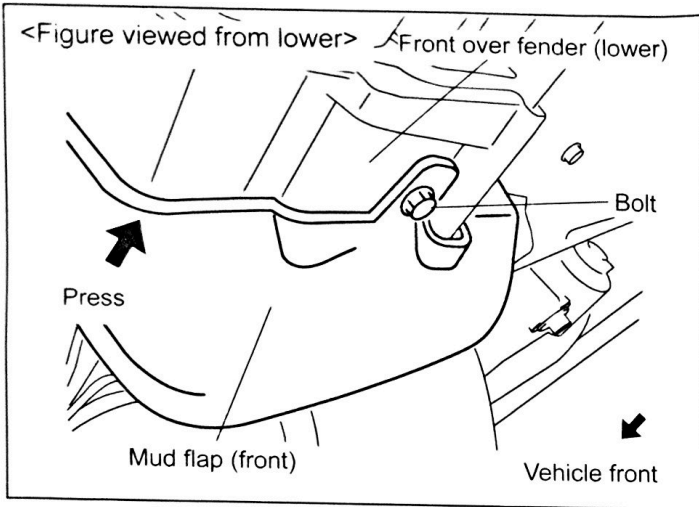

12. While pressing the mud flap (front) in the direction of the arrow in the figure, securely tighten the bolt so that there is no gap between the contacting surface of the front over fender (lower).

Bolt tightening torque: (0.8 to 1.2 Nm)

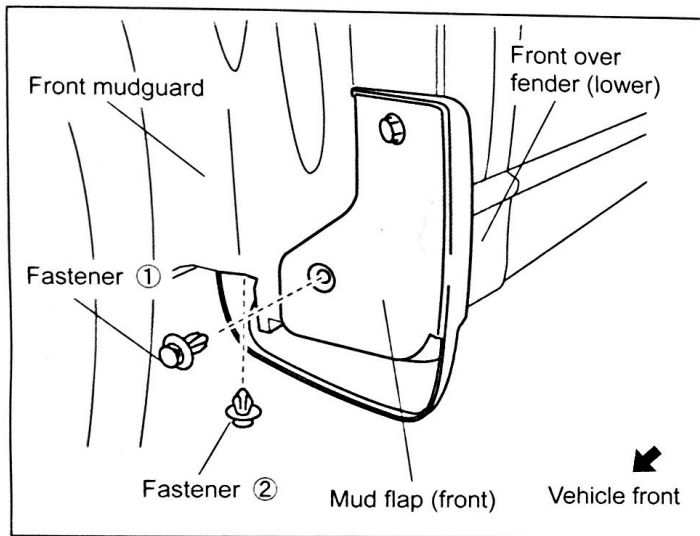

13. Install the mud flap (front) using the fasteners in the order of fastener ① and fastener ② shown in the figure.

5. VERIFICATION AFTER INSTALLATION

1. Verify that there are no gaps.

- If there are gaps, loosen the tapping screw on the front surface and the bolt on the under surface. Follow the instructions in Steps 11 and 12, and retighten the bolts so that there are no gaps between the mud flap (front) and the front over fender and the front over fender (lower).

2. Verify that the bolt and fasteners are securely installed.
3. After verifying that there are no gaps, press the double-sided adhesive tape area firmly.