





GENUINE MUD FLAP (REAR)

INSTALLATION AND USER'S INSTRUCTIONS

Thank you for purchasing a Genuine Mazda Accessory.
Before removal and installation, be sure to thoroughly read these instructions.
Please read the contents of this booklet to properly install and use the mud flap (rear).
Your safety depends on it.
Keep these instructions with your vehicle records for future reference.

WARNING

- There are several  **WARNING** and  **CAUTION** sections in this booklet concerning safety when installing or removing the mud flap (rear). Always read and follow the instructions in order to prevent injuries, accidents, and possible damage to the vehicle.
 -  **WARNING:** Indicates a situation in which serious injury or death could result if the warning is ignored.
 -  **CAUTION:** Indicates a situation in which bodily injury or damage to the vehicle could result if the caution is ignored.
- For areas indicating the tightening torque in this instruction manual, tighten to the specified torque using a torque wrench. For areas in which the tightening torque is indicated inside parentheses (), the tightening torque is indicated as a reference value, however tightening using a torque wrench is not necessary.
- Do not modify the mud flap (rear).
- Do not install the mud flap (rear) in any way other than described in the following instructions.
- If in any doubt, please contact your Mazda dealer to install the accessory in order to prevent errors in installation.
- If you have any questions about the use of the accessory, ask your Mazda dealer for proper advice before using it.
- Mazda and its suppliers are not responsible for injuries, accidents, and damage to persons and property that arise from the failure of the dealer or installer to follow these instructions.
- To ensure safety and reliability of the work, installation, removal and disposal work must be carried out by an Authorized Mazda Dealership.
- Be careful not to lose removed parts, and be sure that they are kept free of dirt, scratches, or damage.

PART NAME: MUD FLAP (REAR)
PART NUMBER: KB7W/KB8M/KB9T V3 460
VEHICLE: MAZDA CX-5

NOTE

To the dealer

- Please give these instructions to the customer after installation.

To the customer

- Keep these instructions after installation. The instructions may be necessary for installing other optional parts or removal of this accessory.
- Should the vehicle or this accessory be resold, always give these instructions to the next owner.



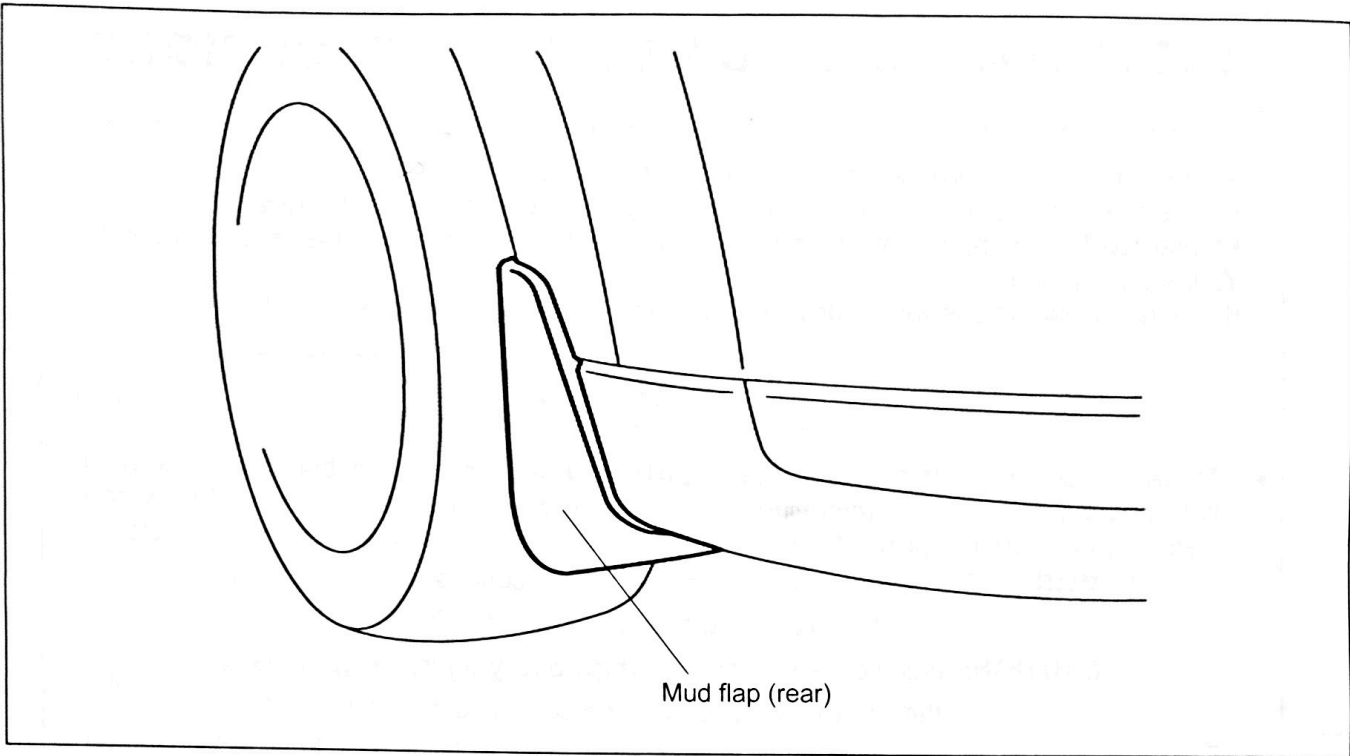

1. INSTALLATION VIEW



2. PARTS

NOTE

- Before installation, verify that the kit includes all the following parts and that they are free of dirt, scratches, or damage.

Part	Part name	Qty	Part	Part name	Qty	Part	Part name	Qty
	Mud flap (rear) RH/LH	1 ea.		Bolt (includes sealant on thread area)	6		Clip nut	6
	Tapping screw (M5x20)	2		Installation and user's instructions	1			

3. VERIFICATION ITEMS BEFORE INSTALLATION

■ REQUIRED TOOLS



- ☆ Phillips screwdriver
- ☆ Socket wrench (8 mm)
- ☆ Fastener remover wrapped with protective tape
- ☆ Utility knife
- ☆ Burr remover
- ☆ Nipper
- ☆ Round file

⚠ WARNING

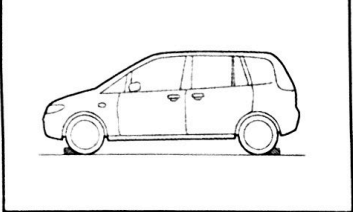
Before performing any work, park the vehicle on level ground, apply the parking brake securely, and then block the wheels. If the vehicle moves while performing work, it may cause injury.

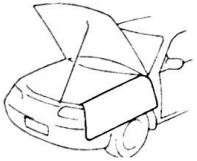
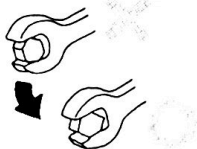

⚠ CAUTION

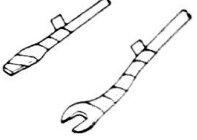
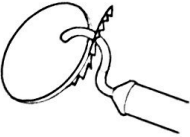
Use masking tape or a protector to prevent scratches when removing/installing parts.	Use the most appropriate (size, use) tool for each task and perform the work correctly. (Otherwise) the parts may be damaged.	Place the removed parts and kit accessories on a protective sheet to prevent scratches.	Wrap protective tape around screwdrivers and fastener remover tools to prevent scratching the vehicle.
			
Make sure to remove burrs. If any burrs remain, deformation will occur.			
			

ADVICE

Refer to the Workshop Manual for removal and installation of applicable vehicle parts.



4. MUD FLAP (REAR) INSTALLATION

• The figure shows the left side, however, perform the same procedure for the right side.

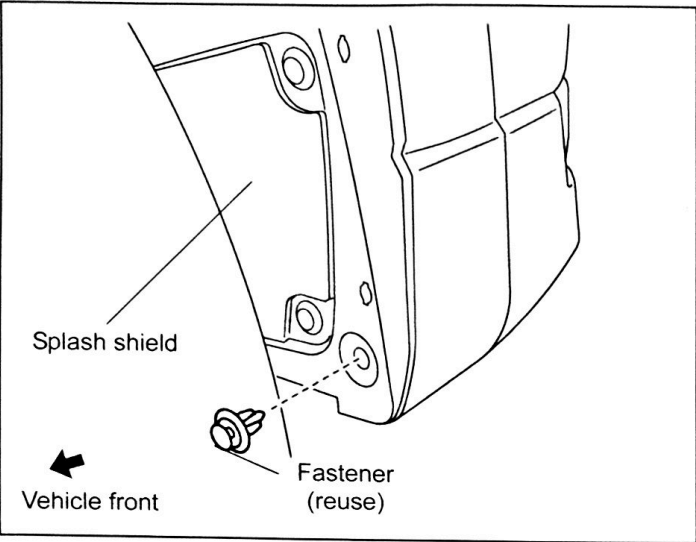

1. Remove the fastener shown in the figure.

• The removed fastener is to be reused.

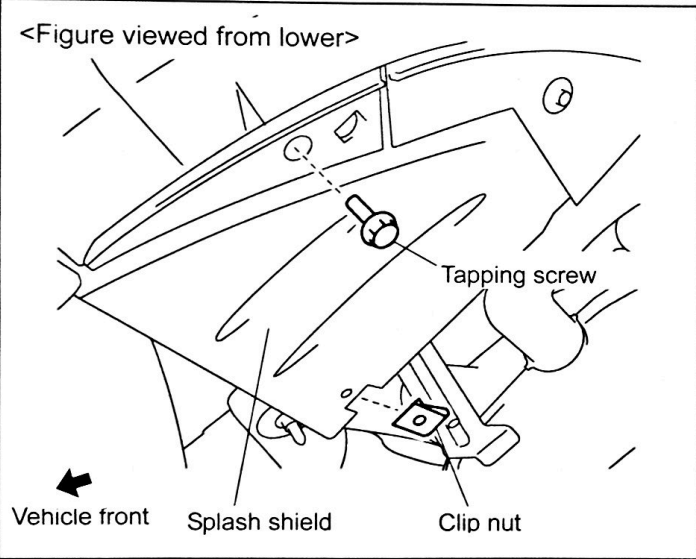

2. Remove the tapping screw from the underside of the splash shield shown in the figure.

• The removed tapping screw is not reused.

3. Install the clip nut to the position shown in the figure by firmly pressing it all the way in until a click sound is heard.

ADVICE
• When installing the clip nut, install it with the flat surface facing downward.

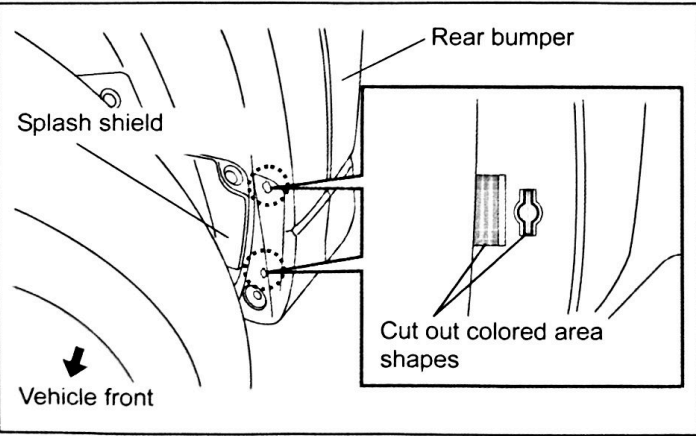

4. Cut out the colored area shapes in the two locations shown in the figure using nippers.

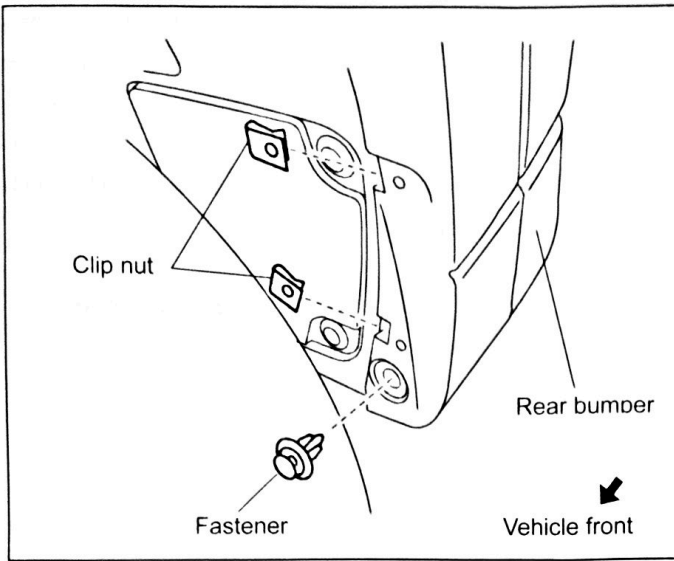

5. Align with the cut positions and install the clip nuts to the two locations by firmly pressing them all the way in until a click sound is heard.

ADVICE

- When installing the clip nut, install it with the flat surface facing downward.

6. Install the reusable fastener removed in Step 1.

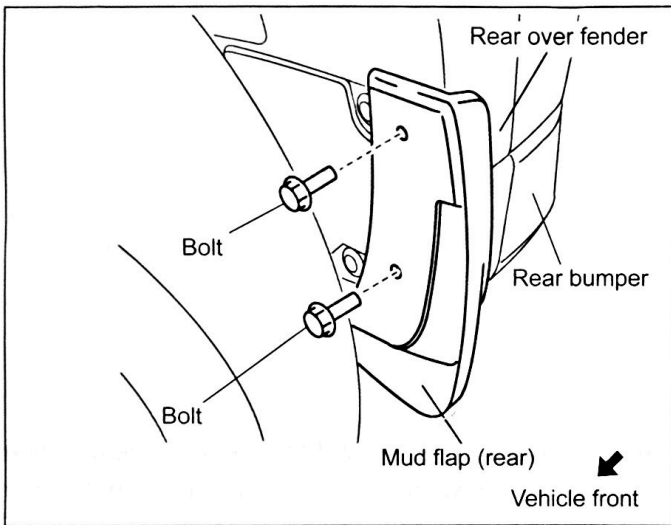

7. Set the mud flap (rear) to the rear over fender and temporarily tighten the bolts and tapping screw.

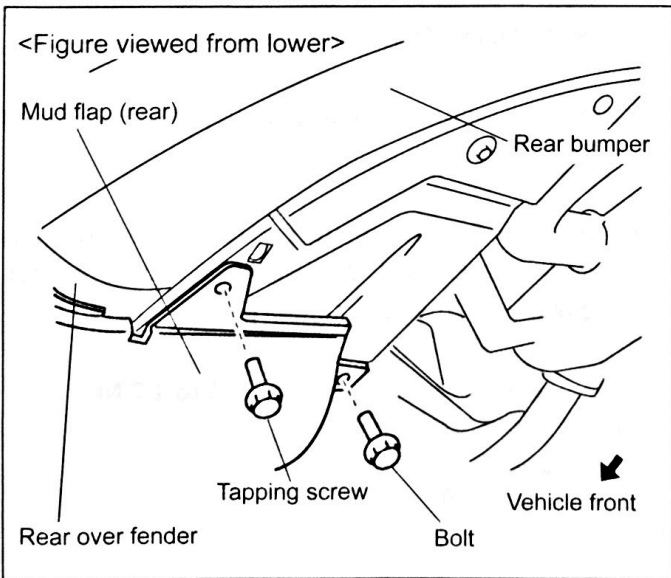

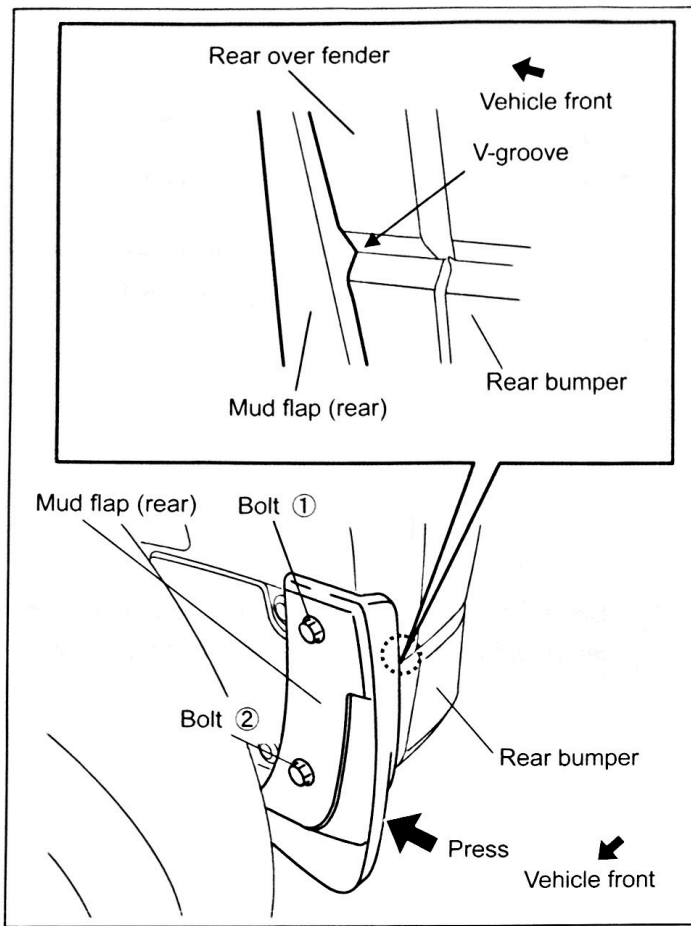

- Press the mud flap (rear) in the direction of the arrow in the figure so that gap between the contacting surfaces at the upper/lower area of the V-groove are uniform. Securely tighten bolt ① so that there is no gap in the contacting surfaces with the rear over fender.

Bolt tightening torque: (0.8 to 1.2 Nm)

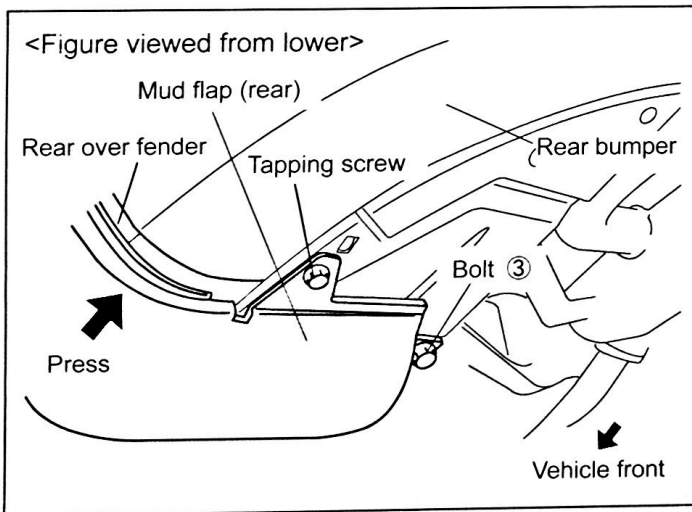

- While pressing the mud flap (rear) in the direction of the arrow in the figure, securely tighten the tapping screw so that there is no gap between the contacting surface of the rear over fender.

Tapping screw tightening torque: (0.8 to 1.2 Nm)

- Securely tighten the mud flap (rear) using the bolts in the order of bolt ② shown in the figure for Step 8 and bolt ③ shown in the figure for Step 9.

Bolt tightening torque: (0.8 to 1.2 Nm)

5. VERIFICATION AFTER INSTALLATION

- Verify that there are no gaps.

- If there are gaps, loosen the three bolts on the front and under surfaces and the tapping screw on the lower surface. Follow the instructions in Step 8 and 9, retighten the bolts so that there are no gaps between the mud flap (rear) and the rear over fender.

- Verify that the bolts, fasteners and plastic nuts are securely installed.